

2/2

HIGH CORROSION RESISTANT VALVES  
202LG SERIES  
DIRECT OPERATED

316L STAINLESS ST.  
PIPE MOUNTING

**NORMALLY OPEN**

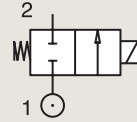

Port size	Orifice Ø	Flow factors		Operating Pressure Differential			Fluid Temp.		Seat Seal	Valve Ref.	Coil Ref.	Power		Coil Group	Dwg. No.
		Kv l/min	KV m <sup>3</sup> /h	Min bar	Max(MOPD) AC bar	DC bar	Min °C	Max °C				AC W	DC W		
1/4"	3.0	4.5	0.27	0	6	6	-10	140	FKM	202LG2NVG7	481865	8	9	24/2.0	3
	5.0	8.0	0.48	0	3	3	-10	140	FKM	202LG2SVG7	481865	8	9	24/2.0	3
1/2"	5.0	8.0	0.48	0	3	3	-10	140	FKM	202LG4SVG7	481865	8	9	24/2.0	3
	6.2	10.0	0.60	0	1	1	-10	140	FKM	202LG4UVG7	481865	8	9	24/2.0	3



For this page	Port size	Orifice (mm)	Kv (l/min)	MOPD (bar)	Fluid Temp (°C)
From	1/4"	3	4.5	1	-10
To	1/2"	6.2	10	6	140

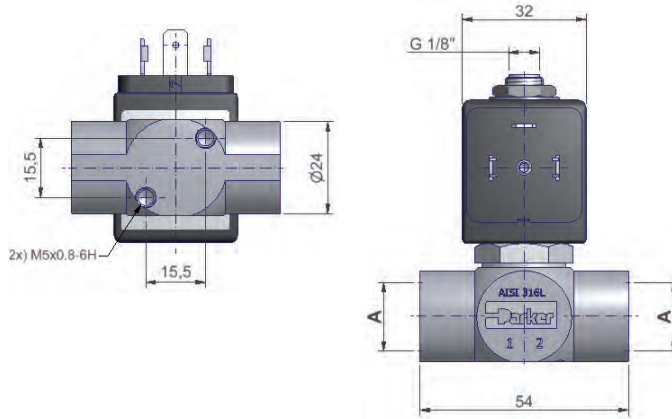

Drawing 3

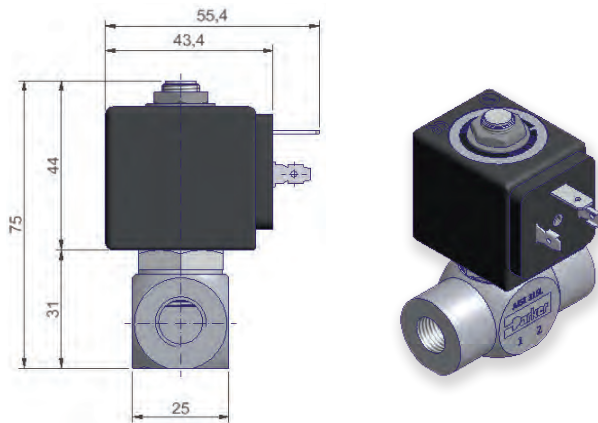

Drawing 3